

Math at Work 11: Chapter 7

February 20, 2012, 17:00

7

Right Triangles and Trigonometry



Keith operates a large crane. He must lift building materials over the houses from the street, and set them down in the work site. He must be sure that the boom and the cable are long enough to do the job safely.

1. What information does Keith know?
2. How can he use similar triangles?
3. How can he use trigonometric ratios?

Key Words

primary trigonometric ratios
angle of depression

Career Link

Bruce runs a construction company. He builds ramps for clients who use wheelchairs. The angle the ramp makes with the ground is important in making sure that the ramp is safe and can be used easily. Bruce uses trigonometry to calculate angles rather than measuring.



Squares

- Evaluate without using a calculator.
 - 2^2
 - 3^2
 - 5^2
 - 10^2
- Estimate. Then, calculate.
 - 5.1^2
 - 6.9^2
 - 2.23^2
 - 10.02^2
 - 62^2
 - 103.5^2
- Evaluate.
 - $3^2 + 4^2$
 - $5.5^2 + 7.8^2$
 - $16^2 - 4^2$
 - $100 - 5^2$
 - $25 + 3^2$
 - $4.02^2 - 2.01^2$

Square Roots

- Calculate. Express your answer to the nearest tenth.
 - $\sqrt{4}$
 - $\sqrt{25}$
 - $\sqrt{68}$
 - $\sqrt{105}$
 - $\sqrt{10.25}$
 - $\sqrt{35.75}$

Right Triangles

- Determine the measure of each unknown angle.

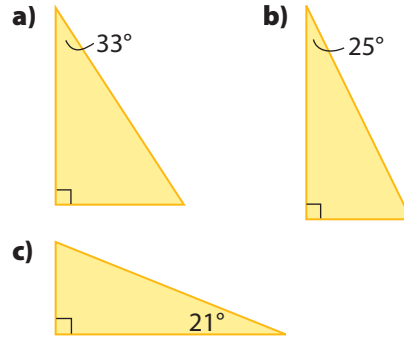

- Determine the length of each unknown. Express your answers to two decimal places, if necessary.

- Bart is building a roof truss. Determine the length of the top beam.

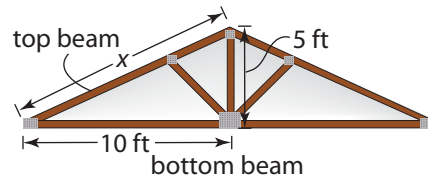

- Dylan is using a moving ramp to load furniture into a truck. Determine the horizontal length of the ramp.

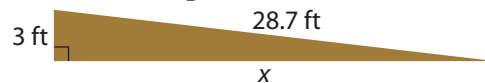

- Tammy is driving her car up a steeply sloped road. Determine the length of the road.

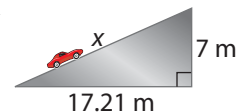

Solve Equations

7. Solve for x . Express your answer to the nearest tenth.

a) $5 = \frac{15}{x}$

b) $3.5 = \frac{10}{x}$

c) $20 = \frac{x}{4}$

d) $2.75 = \frac{x}{5.03}$

e) $10.01x = 2.06$

Trigonometric Ratios

8. State the trigonometric ratios for each angle.

a) $\tan A$

b) $\cos C$

c) $\sin A$

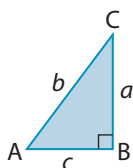

9. a) Estimate the size of $\angle D$, in degrees.

b) Which side is adjacent to $\angle D$? Which side is opposite?

c) Assume that side e measures 10 cm and the hypotenuse measures 25 cm. What trigonometric ratio would you use to find $\angle D$?

d) Use your trigonometric ratio in part c) to calculate the measure of $\angle D$.

e) Compare your calculation for part d) to your estimate in part a). How close were you?



10. Determine the length of each indicated side. Express your answers to two decimal places. The first one is done for you.

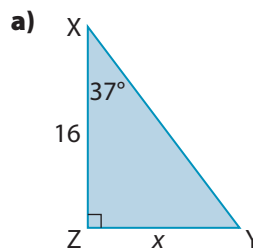

$$\tan 37^\circ = \frac{x}{16}$$

The unknown side is opposite $\angle X$.
The side adjacent to $\angle X$ is 16.
The tangent ratio is opposite divided by adjacent.

Use the tangent ratio:

$$\tan 37^\circ = \frac{x}{16}$$

$$16 (\tan 37^\circ) = \left(\frac{x}{16}\right) 16$$

$$16 (\tan 37^\circ) = x$$

$$12.056\dots = x$$

$$12.06 \approx x$$

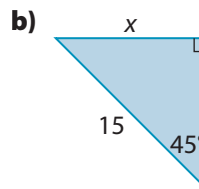

$$\sin 45^\circ = \frac{x}{15}$$

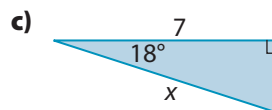

$$\cos 18^\circ = \frac{7}{x}$$

7.1

Right Triangles

Focus On ...

- sketching a given scenario
- using trigonometric ratios to determine distances and lengths
- using trigonometric ratios to determine unknown angles
- solving problems using the three trigonometric ratios



Often, people use trigonometry to calculate the distance between two locations. They do this instead of measuring the distance, which can be time-consuming. You could use trigonometry to calculate the distance between two mountain peaks or other parts of the scenery.

Explore Primary Trigonometric Ratios

Paul works on the ski rescue team for the Woodland Trails Cross-Country Ski Resort. He patrols Run 1 and Run 2, and helps skiers who need assistance or medical help. He carries a map of his patrol area with him.

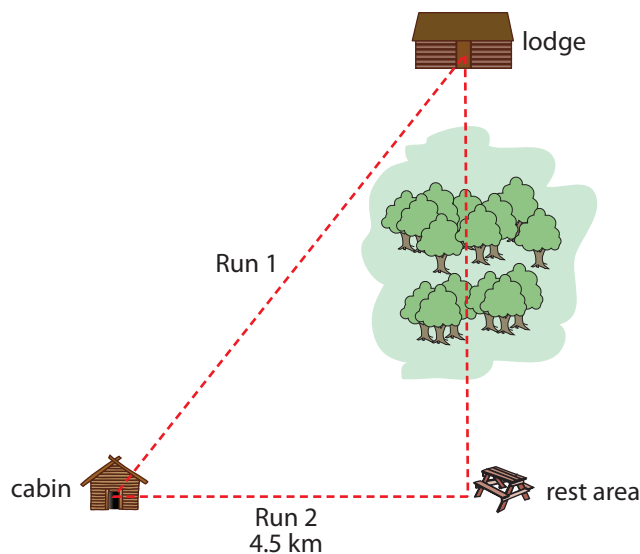

1. What type of shape is formed between the lodge, the cabin, and the rest area?
2. **a)** How can Paul estimate the length of Run 1, without using a measuring device such as a measuring tape or trundle wheel?
b) Paul estimates that the angle between Run 1 and Run 2 is about 30° . Carry out your plan to determine the length of Run 1, to the nearest tenth of a kilometre
3. How can Paul estimate the distance between the rest area and the lodge, without using a measuring device such as a measuring tape or trundle wheel?
4. **Reflect** Could Paul use any of the three **primary trigonometric ratios** to answer steps 2 and 3? Explain.
5. **Extend Your Understanding**

- a)** Describe what Paul should do to determine the total distance he covers when he patrols Run 1 and Run 2, and then returns to the lodge.
- b)** Determine the total distance using the steps you described in part a).



primary trigonometric ratios

- the three ratios defined in a right triangle
- sine, cosine, and tangent

F.Y.I.

The symbol θ is used to mark an unknown angle.

$$\sin \theta = \frac{\text{opposite}}{\text{hypotenuse}}$$

$$\cos \theta = \frac{\text{adjacent}}{\text{hypotenuse}}$$

$$\tan \theta = \frac{\text{opposite}}{\text{adjacent}}$$

On the Job 1

Use the Tangent Ratio to Determine Distance



Walter drives a logging truck for a paper mill near Corner Brook, NL. This sign is posted on the hauling road that leads from the mill to the logging site to warn truck drivers of a very steep slope. The slope of the hauling road Walter uses makes a 5° angle with the ground. The mill and logging site are 2216 m apart, horizontally.



- Draw a diagram of the scenario.
- What side is adjacent to the given angle of the hauling road?
- What side is opposite to the given angle of the hauling road?
- How high is the logging site above the mill?

Solution

- Walter makes a diagram.

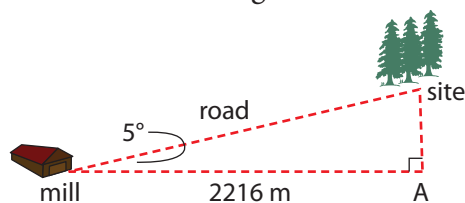

- The horizontal distance between the mill and point A is adjacent to the angle.

Strategy



You can do this type of calculation mentally. $\tan 5^\circ \approx 0.08$. This is about 10%. What number is about 10% of 2216?

F.Y.I.

A forest inventory uses the height of trees to determine their age. This helps researchers determine the health of the forest.

- c) The height of the logging site above the mill is opposite the angle.
- d) Walter writes the information he knows.
- angle of road: 5°
 - distance between mill and point A (adjacent): 2216 m

He can use the tangent ratio to find the height.

$$\tan \theta = \frac{\text{opposite}}{\text{adjacent}}$$

$$\tan 5^\circ = \frac{x}{2216}$$

$$2216 (\tan 5^\circ) = \left(\frac{x}{2216}\right)2216$$

$$2216 (\tan 5^\circ) = x$$

$$193.874\dots = x$$

The logging site is about 194 m above the mill.

Your Turn

Shelby is part of a group of volunteers who are helping with a forest inventory. She uses trigonometry to determine the height of trees that are too tall to measure. The top of a balsam fir tree makes an angle of about 65° with the ground at Shelby's feet. Shelby stands 25 m from the base of the tree. How tall is the tree, to the nearest metre?

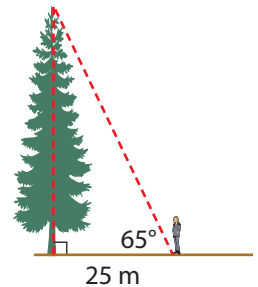

Puzzler

A block staircase has 5 steps and is made up of 30 1 cm-by-1 cm cubes.

- a) How many cubes are needed for a staircase of 12 steps?
- b) How high off the ground is the 12th step?

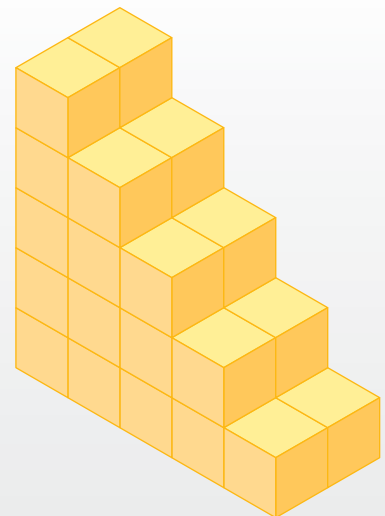

Check Your Understanding

Try It

1. Write the tangent ratio for each angle.

- a) $\angle A$
b) $\angle B$

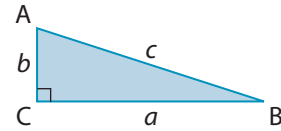

2. Calculate the length of each side x , using the tangent ratio. Express your answer to the nearest tenth of a unit.

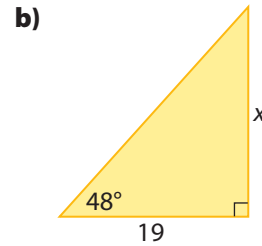
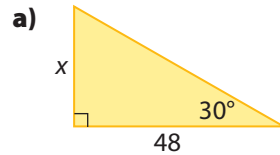

3. Estimate the length of each indicated side. Then, calculate, to the nearest tenth of a unit.

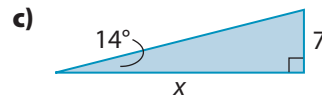
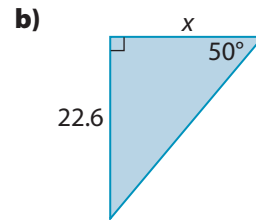
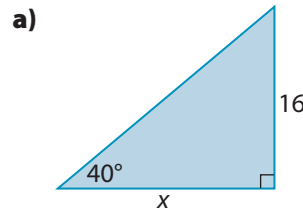

Apply It

4. Nicholas is a scout leader. His scout troop is camping along the banks of Northwest Pond in Camp Nor'Wes, NL. Across the pond from the campsite, there is a dock and a walking trail. The trail leads to cabins where another troop is staying. If the cabins are at a 34° angle from the campsite and the trail is 210 m long, what is the distance across the pond from the campsite to the dock, to the nearest metre?

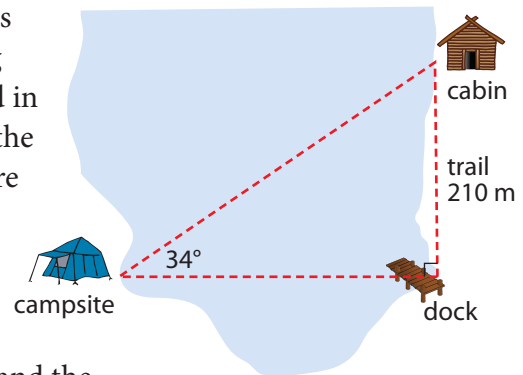

5. The shoreline of Prince Edward Island is made of red sandstone cliffs and sandy beaches. A tourist standing on a beach is 30 m from the base of a vertical cliff. The top of the cliff makes a 60° angle with the ground at the tourist's feet.



- a) Sketch the situation.
b) How high is the cliff, to the nearest metre?
6. Jennie designed a pennant for her sailing club. The pennant is 38.1 cm long, and the angle at the tip is 50° .

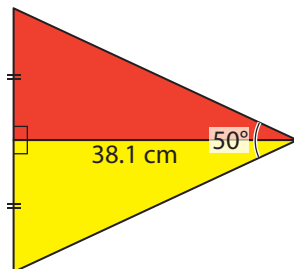

- a) How wide is the base of the red portion of the flag?
b) Jennie has lots of yellow sailcloth but only a 2 m-by-2 m piece of red sailcloth. How many pennants can she make?

On the Job 2

F.Y.I.

To be safe, ladders should be at a 75° with the ground. If the angle is too large, the ladder could fall backward as someone climbs it. If the angle is too small, the bottom of the ladder could slide out. You can judge the angle by using the 1 in 4 rule. For 1 unit away from a wall, go 4 units up the wall.

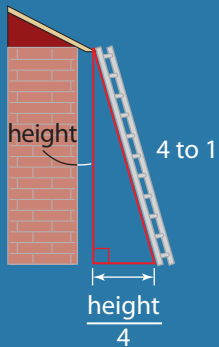

Use the Sine Ratio to Determine Length

A ladder should be placed at a 75° angle to the ground. Elijah has a 16-ft ladder that he wants to use while he repairs a window on the second storey of his house. How high can the ladder reach when used safely? Express your answer to the nearest foot.

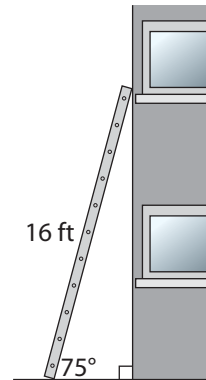

Solution

- angle of ladder: 75°
- length of ladder (hypotenuse): 16 ft

The height the ladder can reach is opposite the angle between the ladder and the ground. Use the sine ratio to calculate x .

$$\sin \theta = \frac{\text{opposite}}{\text{hypotenuse}}$$

$$\sin 75^\circ = \frac{x}{16}$$

$$16 (\sin 75^\circ) = \left(\frac{x}{16}\right)16$$

$$16 (\sin 75^\circ) = x$$

$$16 (0.9659...) = x$$

$$15.455... = x$$

$\sin 75^\circ \approx 0.97$.
This is slightly less than 1. The ladder can safely reach a height slightly less than 16 ft.

The ladder can safely reach a height of about 15 ft.

Your Turn

Elijah borrows an 18-ft ladder from a neighbour. How high can this ladder reach when used safely? Express your answer to the nearest foot.

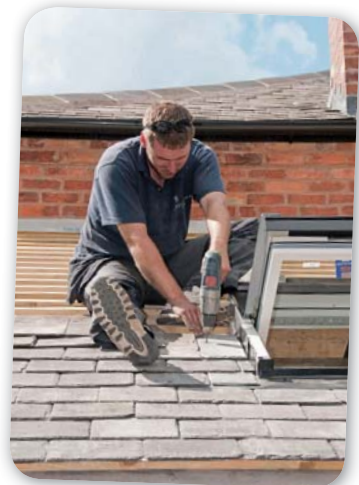

Check Your Understanding

Try It

1. Write the sine ratio for each angle.

a) $\angle A$

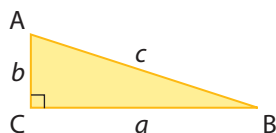

b) $\angle S$

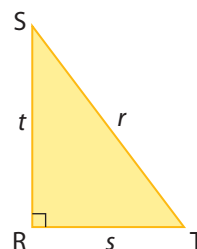

c) $\angle L$

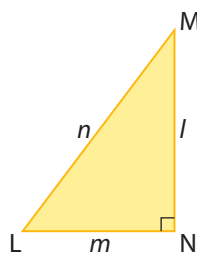

2. Create right $\triangle DEF$, where $\angle E$ is the right angle.

a) Label the side opposite $\angle D$. Label the side adjacent to $\angle D$. Label the hypotenuse.

b) Write the sine ratio of $\angle D$.

3. Estimate the length of each indicated side. Then, calculate, to the nearest tenth of a unit.

a)

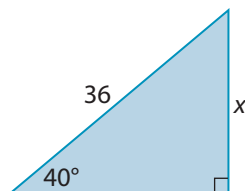

b)

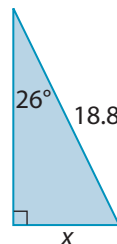

c)

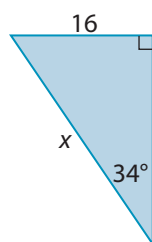

d)

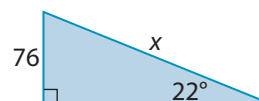

4. What is the length of side AC?
Express your answer to the nearest centimetre.

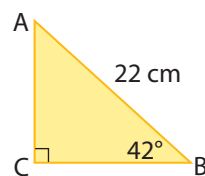

5. In $\triangle RST$, $ST = 14.2$ km, $\angle S = 90^\circ$, and $\angle R = 46^\circ$. What is the length of side RT?
Express your answer to the nearest tenth of a kilometre.

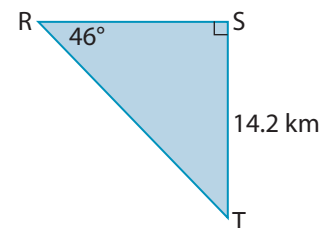

Apply It

6. Sean is building a shed. The angle of the roof truss is 30° . If the top of the truss is 3 ft above the walls of the shed, how long is the slanted part of the truss?



7. A 7-m piece of sheet metal leans against a wall to cover a woodpile. The sheet metal makes an angle of 58° with the ground. At what height does the sheet metal touch the wall?

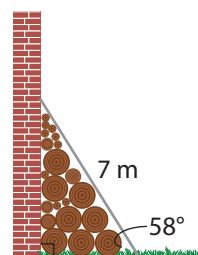

8. Conveyor belts are used in construction and manufacturing to move heavy materials. If the angle of the belt is too steep, the materials on the belt may fall off. A construction company is using an adjustable conveyor belt to move gravel to the top of a pile. The belt is 120 ft long.
- The conveyor belt can be used at angles that are 8° or smaller. What is the highest pile this belt could reach?
 - Another belt is 150 ft long. It can be used at angles that are 10° or smaller. What is the highest pile this belt could reach?



Tools of the Trade

Cartographers make maps to show things such as natural land formations, cities, and roadways. They often work with a Geographical Information System (GIS), which uses satellites to get information about the shape of the land. To learn more about cartographers, go to www.mcgrawhill.ca/school/learningcentres and follow the links.

On the Job 3

Use the Cosine Ratio to Determine an Angle

Jana Lee is a cartographer. She is creating a map of a new housing development. Jana Lee needs to include the angles of intersection on the map. When an intersection is less than 70° , it is called a skewed intersection and she puts a special mark on the map.

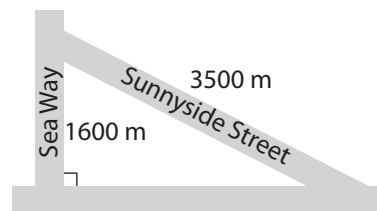

The surveyors forgot to write down the angle formed by Sea Way and Sunnyside Street. She knows the lengths of Sea Way and Sunnyside Street. How can Jana Lee determine if the intersection is a skewed intersection? Calculate the angle between the two streets, to the nearest degree.

Solution

Jana Lee writes the values she knows.

- length of Sea Way: 1600 m
- length of Sunnyside Street (hypotenuse): 3500 m

Sea Way is adjacent to the unknown angle. She can use the cosine ratio.

$$\cos \theta = \frac{\text{adjacent}}{\text{hypotenuse}}$$

$$\cos \theta = \frac{1600}{3500}$$

$$\angle \theta = \cos^{-1}\left(\frac{1600}{3500}\right)$$

$$\angle \theta = 62.797\dots$$

The angle at the intersection of Sea Way and Sunnyside Street is about 63° . This is less than 70° , so it is a skewed intersection.

Your Turn

A highway construction crew is repairing the Kananaskis Trail on-ramp for the Trans-Canada highway in Alberta. The length of the ramp is 450 m, and it joins the highway 300 m from the Kananaskis Trail. What angle does the ramp make with the highway, to the nearest degree?

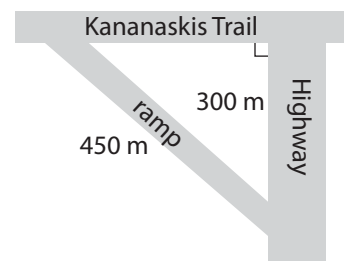

Check Your Understanding

Try It

- Draw right $\triangle LMN$. Make $\angle M$ the right angle.
 - What side is adjacent to $\angle N$?
 - What side is adjacent to $\angle L$?
 - What is the cosine ratio for $\angle N$?
 - What is the cosine ratio for $\angle L$?
- Calculate the length of each side x , to the nearest whole unit.

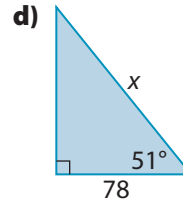
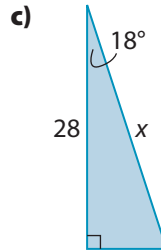
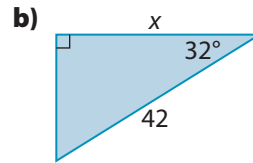
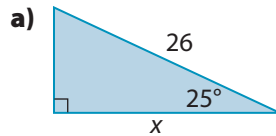

- Use the cosine ratio to determine the unknown angle, to the nearest degree.

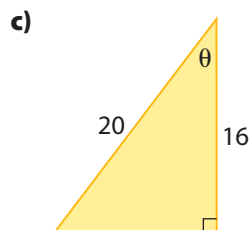
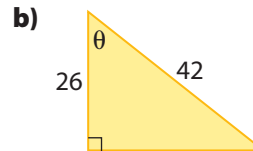
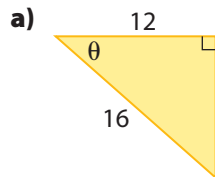

Apply It

4. Letha works as an outdoor education instructor. For an orienteering day, she places markers in the woods that participants must find using a map and compass. She puts marker B directly across the stream from marker A. She puts marker C 100 m from marker B on the same side of the stream. If marker C is 175 m from marker A, what is the measure of $\angle C$, to the nearest degree?

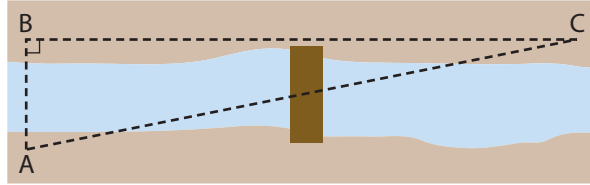

F.Y.I.

The highest mountain on Earth, Mount Everest, is in Nepal.

5. The national flag of Nepal is the only flag that is not a quadrilateral. It is in the shape of two stacked right triangles. The base of each triangle is the same.
- What is the angle of the top vertex of the flag ($\angle A$)?
 - What is the angle of the vertex on the right side of the flag ($\angle C$)?

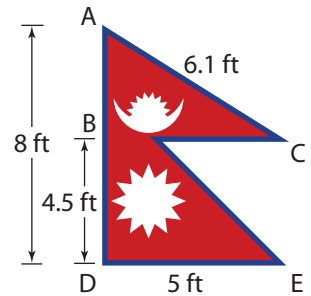

6. In very large airports, such as Toronto Pearson International Airport, adjustable conveyor belts are used to move passengers' bags through the airport terminal. The vertical sorter shown here can be adjusted to put baggage on the top conveyor belt or the bottom conveyor belt. It can reach an angle of 18° above or below the middle conveyor belt.

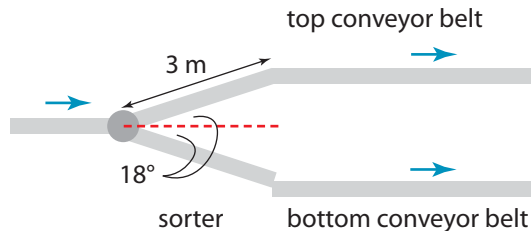

The airport purchases a 3-m long vertical sorter. How far, horizontally, from the middle conveyor belt does the top conveyor belt need to be installed in order for the sorter to reach?



Tools of the Trade

Surveyors use a piece of equipment called a theodolite to measure angles between objects. To learn more about theodolites and surveying, go to www.mcgrawhill.ca/school/learningcentres and follow the links.

F.Y.I.

A compass rose is used to display the directions on a map. North usually points to the top of the map or diagram.

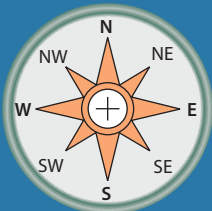

Work With It

- Surveyors use reference points and measurements to calculate long distances. Sonja is a surveyor working on a property. She places a marker at the end of the property. She sets up her surveying equipment 800 m from the property's end, on the opposite side of the property. Using the equipment, she views the marker at a 62° angle from the end of the property.
 - What information does Sonja know? Provide a diagram.
 - How wide is the property? Express your answer to the nearest metre.
- A clothesline pole is supported by a guy wire attached to the top of the pole. The wire makes a 31° angle with the ground.
 - What angle does the wire make with the pole?
 - The wire is attached to the ground 4.2 m from the base of the pole. How tall is the pole, to the nearest metre?
- Anna and Peter leave their home in Gander, NL. Anna drives 11.5 km north on Northview Avenue to the grocery store. Peter walks 3.5 km east along East River Drive to the park.

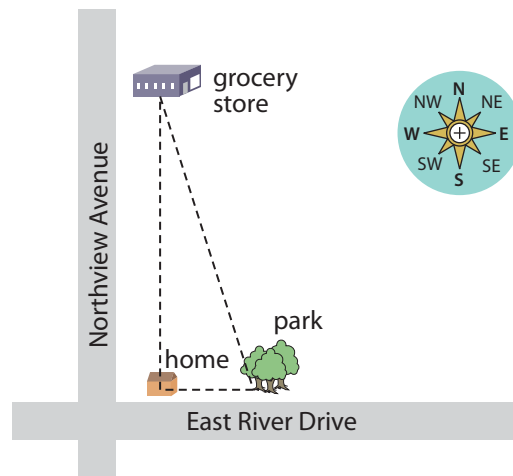

- How far apart are Anna and Peter? Express your answer to the nearest tenth of a kilometre.
- At the park, Peter can see the grocery store. What is the angle formed between Anna's and Peter's home, the park, and the grocery store?

Discuss It

4. Oliver was calculating the length of side AC in the triangle. A partial solution is shown.

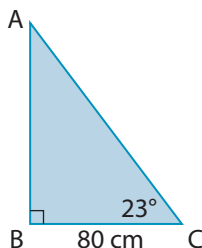

$$\sin 23^\circ = \frac{80}{AC}$$

$$AC (\sin 23^\circ) = \left(\frac{80}{AC}\right)AC$$

$$AC (\sin 23^\circ) = 80$$

$$\frac{AC (\sin 23^\circ)}{\sin 23^\circ} = \frac{80}{\sin 23^\circ}$$

$$AC = \frac{80}{\sin 23^\circ}$$

- a) Before he completed his work, Oliver noticed that he had made an error. Identify Oliver's error.
- b) What is the correct way for Oliver to calculate the length of side AC? Explain how you know.

Strategy



**Work
Backward**

5.



If I know the length of two sides of a right triangle, I can use the cosine ratio to solve for an unknown angle.

Is Chelsea correct? Why or why not? Discuss the possibilities with a partner.

7.2

Angles of Elevation and Depression

Focus On ...

- identifying and sketching a given scenario
- using angles of elevation and depression to determine distances and lengths
- using trigonometric ratios to determine unknown angles of elevation and depression
- solving problems using angles of elevation and depression

Some objects, such as towers or statues, are too tall to measure directly. How can trigonometry help?

Explore Angles of Elevation

Materials

- measuring tape

- 1. a)** Work with a partner outside on a sunny day. Measure and record the height of your partner.
b) Measure and record the length of your partner's shadow.
- 2.** Sketch a diagram of the scenario. Label the diagram to show what you have recorded.

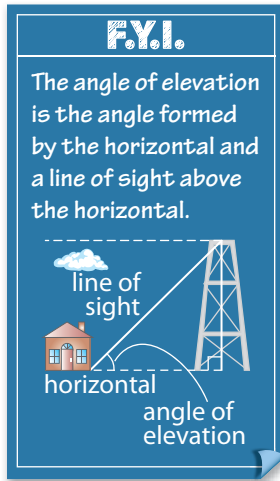

3.
 - a) On your diagram, label the hypotenuse and the sides adjacent to and opposite the angle formed between the sun's rays and the top of the head of the shadow.
 - b) What trigonometric ratio could you use to solve for the unknown angle?
4.
 - a) Estimate the angle of elevation of the sun.
 - b) Use trigonometry to confirm the angle of elevation of the sun.
 - c) How close was your estimate?
5. **Reflect** What mathematical strategies could you use to determine the height of your school, using the information from steps 3 and 4?
6. **Extend Your Understanding** Use the angle of elevation you calculated in step 4b) to determine your height, based on the length of your shadow.
7. Repeat this experiment at a different time of day. How do your calculations change?

Puzzler

Could you use your information from the Explore to determine the distance from the tip of your shadow to the sun? Why or why not? Use a diagram to help you explain your response.

On the Job 1

Determine Distance Using an Angle of Elevation



Natalie runs a scenic chairlift ride that overlooks part of Marble Mountain, NL. Tourists get on the chairlift at the bottom, and take the 1800-m long ride up the mountain. The cables that the chairs ride have a 36° angle of elevation. A tourist wants to know the horizontal distance the ride travels. What is this horizontal distance, to the nearest metre?

Solution

Natalie makes a diagram of the chairlift ride.

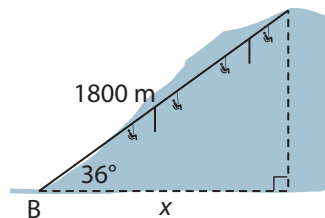

She notices that she cannot measure the horizontal distance the ride travels because it travels up a slope, so the horizontal distance is under the ground. She will need to use trigonometry.

Natalie writes down the things she knows.

- length of ride (hypotenuse of triangle): 1800 m
- angle of elevation (angle B): 36°

Natalie needs to determine the length of the side of the diagram that is adjacent to the angle of elevation. This is side x . Because she knows the hypotenuse, she uses the cosine ratio.

$$\cos B = \frac{\text{adjacent}}{\text{hypotenuse}}$$

$$\cos 36^\circ = \frac{x}{1800}$$

$$1800 (\cos 36^\circ) = \left(\frac{x}{1800}\right)1800$$

$$1800 (\cos 36^\circ) = x$$

$$1456.2\dots = x$$

The horizontal distance the ride covers is about 1456 m.



Tools of the Trade

Airport cargo agents often need to load vehicles and construction equipment into cargo holds that are a distance off the ground. They pull the vehicles up the ramp using winches and load binders. To learn more about airport cargo agents, go to www.mcgrawhill.ca/school/learningcentres and follow the links.

Your Turn

Callum is a cargo agent at an airport. He loads and balances equipment and cargo inside airplanes. He uses a ramp that is 5.1 m long to load cargo onto the planes. The angle of elevation of the ramp is 7° .

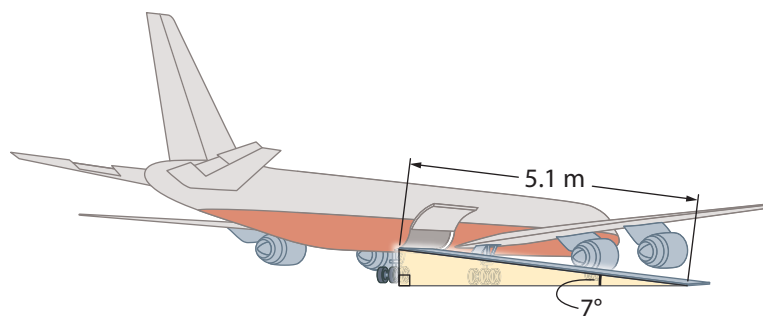

How high is the cargo door of the airplane above the ground? Express your answer to the nearest tenth of a metre.

Check Your Understanding

Try It

1. For each angle of elevation, which trigonometric ratio can be used to determine the length of the indicated side?

a)

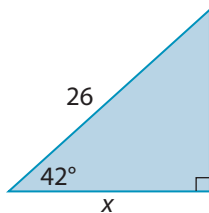

b)

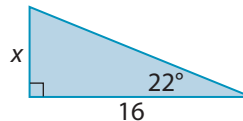

c)

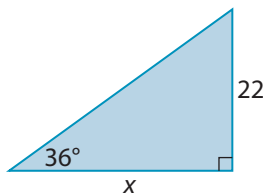

d)

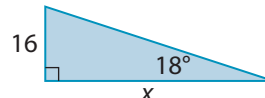

e)

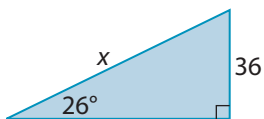

f)

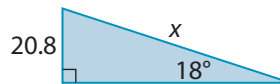

2. Determine each unknown length in #1. Express your answers to the nearest whole unit.
3. Create a diagram for each of the following scenarios.
- Keisha is helping her neighbour move. The ramp to the moving truck is 3 m long, and makes an angle of 32° with the ground. Keisha wants to know if she can lift boxes from the ground into the truck without using the ramp. How high is the loading door of the truck off the ground?
 - Aaron is a leisure pilot. His plane takes off from an airport at an angle of 6° with the ground. He flies 5.4 km until he is over a lake. What is the horizontal distance from the airport to the point in the lake that is directly below Aaron's plane?
 - Janie is displaying a kite that she made. The kite is attached to a stake in the ground. The kite is 32 m above the ground, and it makes an angle of 40° with the ground. How long is the kite string?
4. Identify the trigonometric ratio you could use to solve each problem in #3.



Tools of the Trade

A clinometer is an instrument used to determine an angle of elevation or depression.



For more information about clinometers and how to use them, go to www.mcgrawhill.ca/school/learningcentres and follow the links.

Apply It

- A telecommunications tower is being installed on the top of a mountain. A guy wire will be attached to the top of the 15-m tower for support. The wire has an angle of elevation of 57° . How much wire will the installation crew need to take with them, to the nearest metre?
- Sally lives in Halifax, NS. She is editing an article for an online encyclopedia.

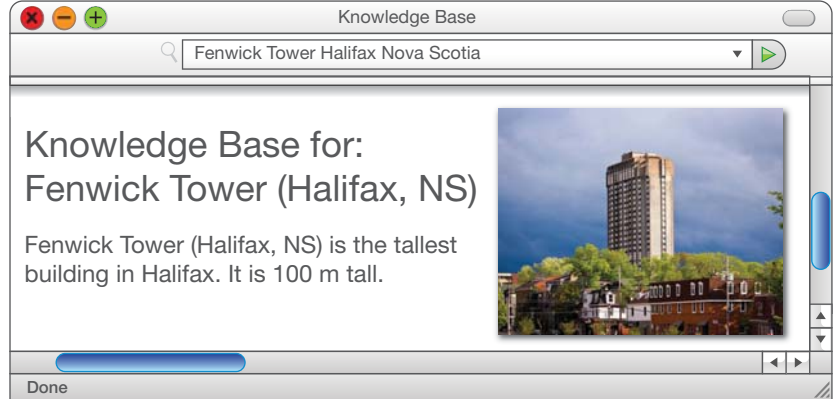

To confirm the height of Fenwick Tower, Sally stands 25 m back from the base of the building. She uses a clinometer at an angle of 75° to view the top of the building.

- Draw a sketch of the scenario.
- What trigonometric ratio could Sally use to find the height of Fenwick Tower?
- How accurate do you think Sally's calculation is? Explain.

- Orlando is looking at a flyer for a home-improvement store. He wants to buy a ladder to use around his home. The highest point of his two-storey house is 24 ft. Ladders must have an angle of elevation of 75° to be used safely.

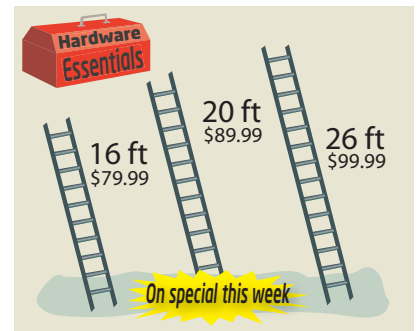

- Which ladder could reach the highest point of Orlando's house safely?
- Orlando's neighbour offers to lend him a 24-ft extension ladder so he does not have to buy one. The neighbour says that Orlando can use this ladder safely to reach the highest point of his house. Is this correct? Why or why not?

On the Job 2

Determine Distance Using an Angle of Depression

Emily is touring historical lighthouses in Nova Scotia. While she is at the top of the Peter Island lighthouse, she notices that she can see Sweetcake Cove across the water to the southwest. The lighthouse is 13 m high and its base is 19 m above the water. Emily estimates that she looks down at the cove with an **angle of depression** of 5° . What is the approximate horizontal distance from the lighthouse to Sweetcake Cove, to the nearest metre?

angle of depression

- angle formed by the horizontal and a line of sight below the horizontal line

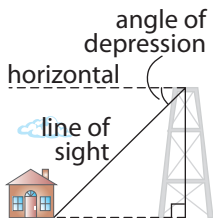

Solution

Sketch the scenario.

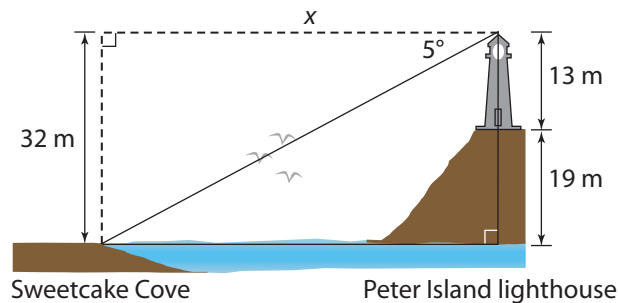

Write the known values.

- height of lighthouse: 13 m
- height of lighthouse above water: 19 m
- angle of depression: 5°

$$\begin{aligned} \text{length of opposite side} &= \text{height of lighthouse} + \text{height of lighthouse above water} \\ &= 13 + 19 \\ &= 32 \text{ m} \end{aligned}$$

The horizontal distance between the lighthouse and the cove is the side adjacent to the angle of depression. Use the tangent ratio.

$$\tan \theta = \frac{\text{opposite}}{\text{adjacent}}$$

$$\tan 5^\circ = \frac{32}{x}$$

$$x(\tan 5^\circ) = \left(\frac{32}{x}\right)x$$

$$x(\tan 5^\circ) = 32$$

$$\frac{x(\tan 5^\circ)}{\tan 5^\circ} = \frac{32}{\tan 5^\circ}$$

$$x = \frac{32}{\tan 5^\circ}$$

$$x = 365.761\dots$$

The horizontal distance from the Peter Island lighthouse to Sweetcake Cove is about 366 m.

Your Turn

While still on her tour, Emily notices Westport Harbour to the northwest. If she looks down at an angle of depression of 3° , what is the horizontal distance from the lighthouse to Westport Harbour, to the nearest metre?



Check Your Understanding

Try It

1. What trigonometric ratio would you use to determine each unknown side?

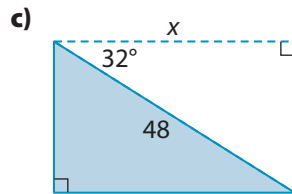
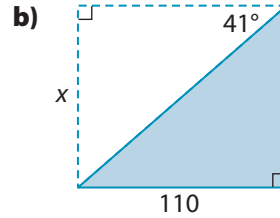
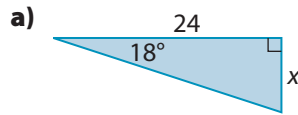

2. Determine the length of each unknown side. Express your answer to the nearest whole unit.

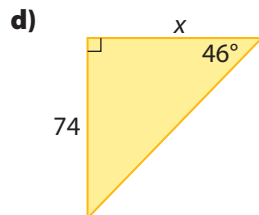
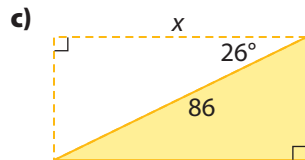
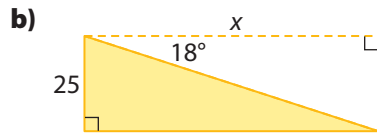
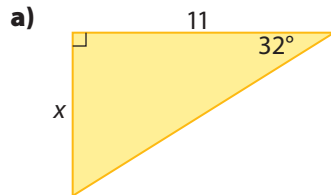

Apply It

3. Ben drives an excavator. His job is to dig holes in the ground for basements or swimming pools. He uses a sloped ramp leading down into the excavation area to get his machine safely into and out of the hole. This angle of depression is 30° . The excavation is 10 feet deep.

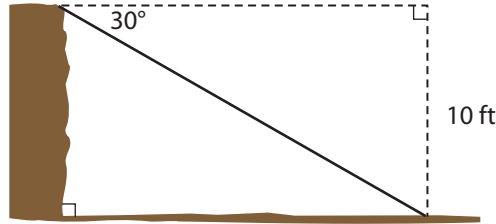

- a) What trigonometric ratio would you use to find the length of the ramp?
- b) Calculate the length of the ramp, to the nearest foot.
4. A guy wire supporting a tower must be attached to the tower at an angle of depression of 75° . The guy wire is anchored to the ground 6 m from the base of the tower.
- a) What angle does the wire make with the tower? How do you know?
- b) How tall is the tower, to the nearest metre?
5. A security camera is installed on an 8-m pole above a parking lot to watch the entrance to a convenience store. The pole is 20 m from the entrance. The camera operates properly at an angle of depression of 25° .
- a) At the correct operating angle, how far, horizontally, can the camera's view reach?
- b) Can the camera's view reach the entrance? If not, what height of pole should the camera be installed on to monitor the entrance?
6. From the top of a bridge over the Victoria River in Newfoundland and Labrador, Maria looks down at a sailboat at an angle of depression of 13° . The bridge is 22 m above the water.
- a) Estimate the horizontal distance from the bridge to the sailboat.
- b) Calculate the horizontal distance from the bridge to the sailboat. Express your answer to the nearest metre.
- c) How does your calculation compare to your estimate? Explain.

On the Job 3

Determine an Angle of Depression



Laurie is a crew member on a tall ship that sails Bay of Islands, NL. She often sits in the crow's-nest on top of the main mast. The main mast of the ship is supported by shrouds, which run from the top of the mast to the hull of the boat. To make sure the mast is properly supported, the shroud must be attached to the top of the mast at an angle of depression of 78° . The mast of the tall ship is 150 ft tall. Laurie notices that the shroud is secured 22 ft from the base of the mast.

Does the shroud form the correct angle of depression to support the mast? If not, determine how far from the base of the mast the shroud must be secured to make the correct angle of depression. Express your answer to the nearest foot.

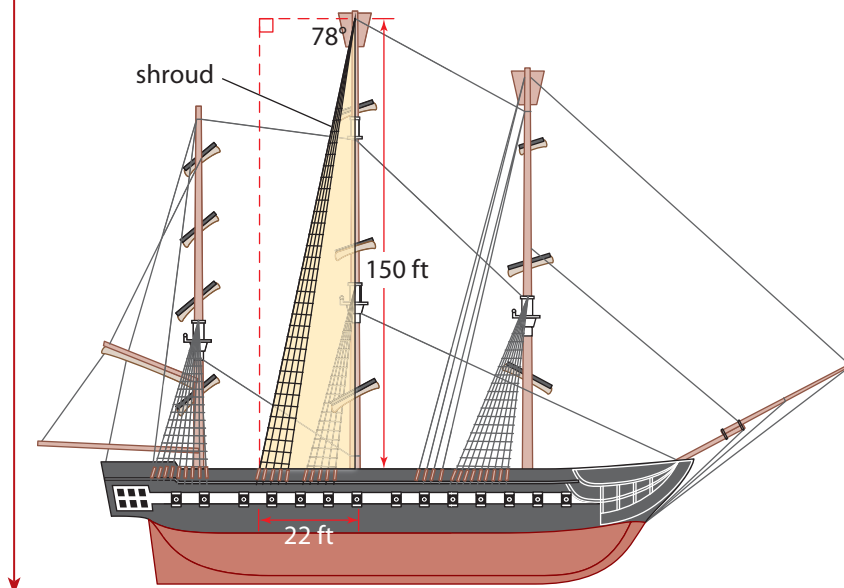

Solution

- height of mast (vertical): 150 ft
- distance of shroud from base of mast (horizontal): 22 ft

Because Laurie knows the sides adjacent and opposite to the angle of depression, she uses the tangent ratio.

$$\tan \theta = \frac{\text{opposite}}{\text{adjacent}}$$

$$\tan \theta = \frac{150}{22}$$

$$\theta = \tan^{-1} \left(\frac{150}{22} \right)$$

$$\theta = 81.656\dots^\circ$$

The angle of depression of the shroud is about 82° . The shroud does not form the correct angle to support the mast.

The angle of depression of the shroud needs to be 78° . Laurie can calculate the distance from the base of the mast where the shroud must be secured using the tangent ratio.

$$\tan \theta = \frac{\text{opposite}}{\text{adjacent}}$$

$$\tan 78^\circ = \frac{150}{x}$$

$$x (\tan 78^\circ) = \left(\frac{150}{x} \right) x$$

$$\frac{x \tan 78^\circ}{\tan 78^\circ} = \frac{150}{\tan 78^\circ}$$

$$x = \frac{150}{\tan 78^\circ}$$

$$x = 31.883\dots$$

$$\tan 78^\circ \approx 5.$$

$$\frac{150}{x} \approx 5.$$

$$x \text{ is about } 30.$$

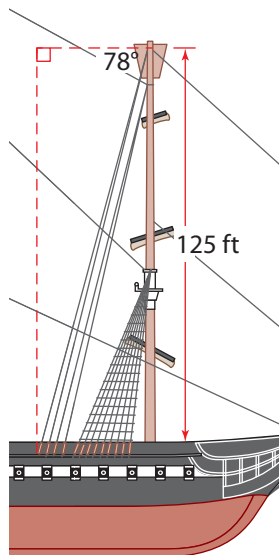

The shroud should be secured about 32 ft from the base of the mast.

Your Turn

The foremast of the tall ship is also supported by shrouds. The foremast is 125 ft tall, and its shroud is secured 20 ft from the base of the mast. Laurie sits in the crow's-nest of the foremast to check the angle of depression of the shroud. The shroud must make an angle of depression of 78° .

Does the shroud form the correct angle of depression to support the mast? If not, determine how far from the base of the mast the shroud must be secured to make the correct angle of depression, to the nearest foot.

Check Your Understanding

Try It

1. Which trigonometric ratio would you use to solve for the indicated angle?

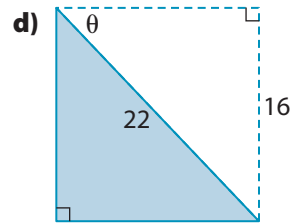
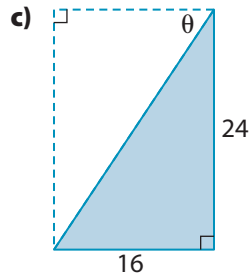
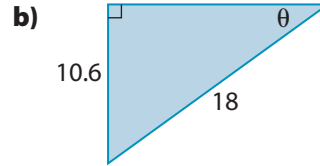
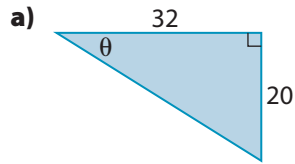

2. Determine each angle measure, to the nearest degree.

- a) $\cos^{-1}(0.7451)$
- b) $\tan^{-1}(2.345)$
- c) $\sin^{-1}(0.5)$
- d) $\tan^{-1}(0.9364)$

3. Calculate the measure of each angle, to the nearest degree.

- a) $\cos A = 0.0246$
- b) $\tan B = 0.4579$
- c) $\sin C = 0.3276$
- d) $\cos D = 0.6$

4. Solve for each indicated angle to the nearest degree.

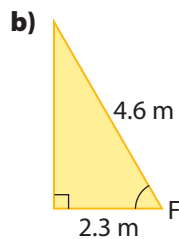
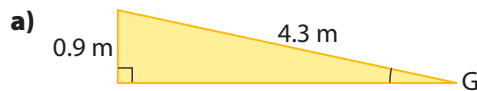

Apply It

5. Alan and Amy are part of a charity that builds playgrounds for young children. They are studying the playground designs to make sure they meet safety specifications before building starts. They use a table to organize their findings.

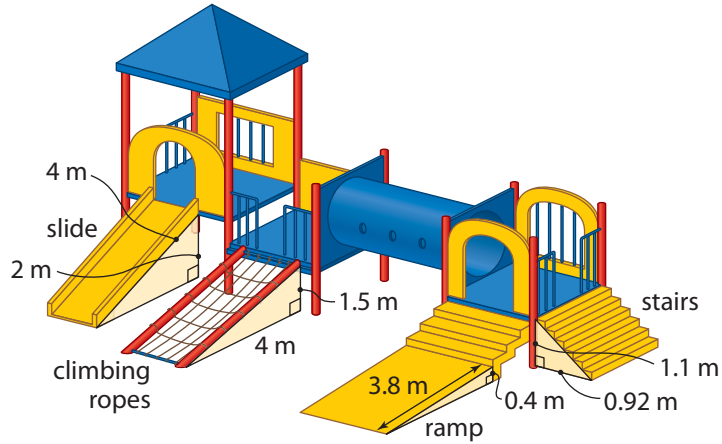

Playground Part	Safe Angle	Actual Angle (°)	Safe? (Yes/No)
Slide	Angle of depression of 50° or less		
Staircase to bridge	Angle of elevation of 35° or less		
Ramp	Angle of elevation of 7° or less		
Climbing ropes	Angle of depression of 75° or less		

- a) Copy the table in your notebook. Then, complete the table.
- b) Are all the parts of the proposed playground safe? Why or why not?
6. On a clear, calm day, the weather report says that the cloud ceiling is 900 ft. Daria launches a ceiling balloon and confirms the report. After two minutes, the balloon disappears into the cloud ceiling. The balloon is 1500 ft from the launch site when it disappears.

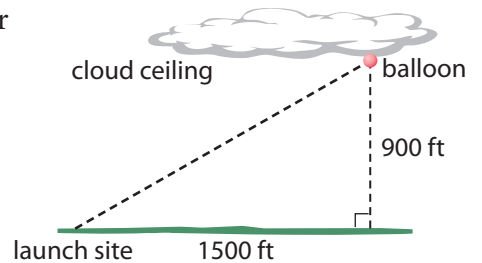

- a) How fast was the balloon rising, in feet per minute?
- b) What is the angle of elevation of the balloon? Express your answer to the nearest degree.

Work With It

- Chris attaches a floodlight to the top of his barn, which is 7 m high. The light shines down with an angle of depression of 48° .
 - The driveway to the barn is 13 m long. Will the floodlight be able to light the entire length of the driveway?
 - Chris estimates that he can light an area twice the distance away from the barn by lowering the angle of depression by half, to 24° . Is this a reasonable estimate? Why or why not?
- Cape Beale Lighthouse, BC, is on a cliff that is 51 m above sea level. The lighthouse warns boats of rocks close to shore. The lighthouse is 10 m high. The safe distance for boats from the shore is 75 m. The lighthouse keeper looks out and sees a boat. She estimates that the angle of depression of the boat is 50° .
 - Sketch a diagram of this scenario.
 - Is the boat a safe distance from shore? Show your work.
- Jake and Henry need to cut down a tree in a neighbour's yard. They want to drop it where it will miss a building and a fence that are both nearby. To help, they need to determine the height of the tree. Jake stands 14 m from the base of the tree. Using a clinometer, he determines that the angle to the top of the tree is 31° .
 - Sketch a diagram of this scenario.
 - Determine the height of the tree, to the nearest tenth of a metre.



Discuss It

4. Jessica and Weston are arborists. While working up in a tree, Jessica can see Weston. She estimates the angle of depression from herself to Weston. At the same time, Weston estimates the angle of elevation from himself to Jessica.

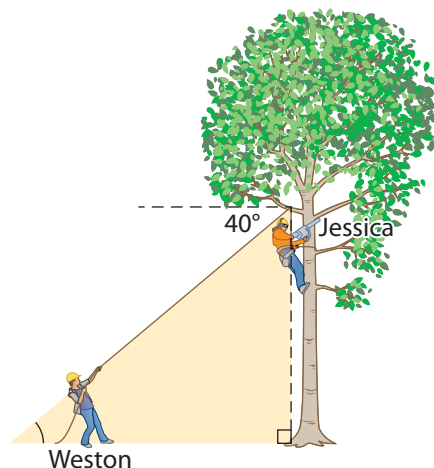

- a) Weston says that because the angle of depression from Jessica to him is 40° , his estimated angle of elevation must be greater than 40° . Is he correct? Explain your reasoning.
- b) In order to correctly measure the angle of elevation from himself to Jessica, Weston can use any of these measurements:
- the height of Jessica above the ground
 - the horizontal distance between Weston and the tree
 - the length of the line of sight
 - Jessica's measurement of the angle of depression

Which of these measurements would you use? Explain how you would use them to correctly calculate the angle of elevation.

5. How are the angle of elevation and the angle of depression related? Show how you know.
6. Jody says that an angle of elevation and its corresponding angle of depression are complementary angles.
- a) Explain what Jody means.
- b) Is Jody's statement correct? Why or why not?
7. Alan is using a 30-ft ladder to do some repairs around his house. He does not have a measuring tape.
- a) If the ladder must be used at a 75° angle to be safe, how can he estimate how far from the wall the base of the ladder must be? Explain and show examples.
- b) If Alan uses a 24-ft ladder, how can he estimate how far from the wall the base of the ladder must be?

FYI!

Complementary angles are two angles that add to 90° . They form a right angle.

$$\cos 75^\circ \approx 0.25$$

7.3

Multiple Right Triangles



Focus On ...

- identifying right triangles in a given scenario
- using trigonometric ratios to determine unknown angles and lengths
- determining whether a solution to a problem is reasonable

Right triangles are used often in modern architecture. How many triangles can you spot?

Explore Multiple Right Triangles

Materials

- square piece of paper
- ruler
- protractor

1. Fold the piece of paper according to these steps:
 - Label the corners of the paper A to D.
 - Fold the paper in half, and then unfold it.
 - Fold corner B until it touches the middle crease line. Crease the paper with a ruler or your fingernail.
 - Fold corner C until it touches the fold line. Crease the paper.
 - Tuck corner D under the other folds. Crease the paper.

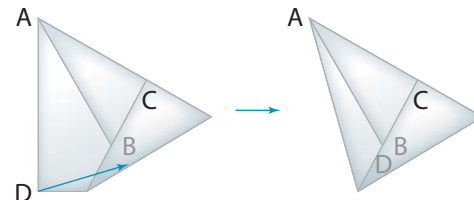
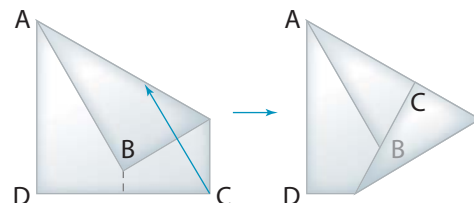
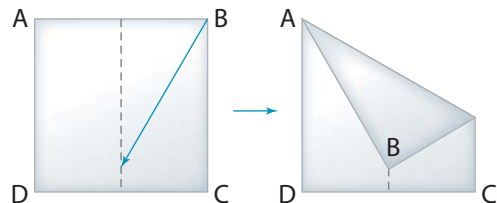
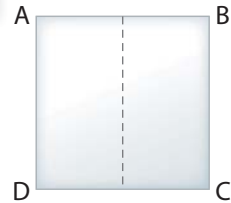

- 2. a)** Outline as many triangles as you can find on your folded piece of paper.
- b)** Mark any of the 90° angles with a square.
- c)** Label the 90° triangles A, B, and so on.
- 3. a)** Measure the side lengths of triangle A. Record the lengths on the triangle.
- b)** Estimate the measure of one angle of triangle A.
- 4. a)** Use trigonometry to calculate the measure of the angle you estimated in step 3b). Record the measure on the triangle.
- b)** Confirm your angle measurement with a protractor.
- c)** How close were your estimate, calculation, and measurement?
- 5.** Repeat steps 3b) and 4 with the second angle in triangle A.
- 6. a)** Use a protractor to measure one angle in triangle B. Measure the length of the hypotenuse. Record your measurements on the triangle.
- b)** Estimate the length of one side of triangle B.
- 7. a)** Use trigonometry to calculate the length of the side you estimated in step 6b). Record the measure on the triangle.
- b)** Confirm your length measurement with a ruler.
- c)** How close were your estimate, calculation, and measurement?
- 8.** Repeat steps 6b) and 7 with the second side in triangle B.
- 9. Reflect**
 - a)** How many other triangles are visible on your folded paper?
 - b)** Can you use trigonometry to calculate the lengths of the sides of each triangle? Why or why not?
- 10. Extend Your Understanding**
 - a)** In triangle A, the measure of one of the angles was unknown. How could you have determined the angle measure without using trigonometry? List as many methods as you can.
 - b)** In triangle B, the length of one of the sides was unknown. How could you have determined the side length without using trigonometry? List as many methods as you can.

On the Job 1

Solve for Distance in Multiple Triangles

Renée works as a bridge inspection assistant for an engineering firm in St. John's, NL. As part of her job, she needs to continuously practise making the measurements and calculations she uses when inspecting in-service bridges. One day, she uses a diagram of the Alex Fraser Bridge in Richmond, BC, to practise making measurements.

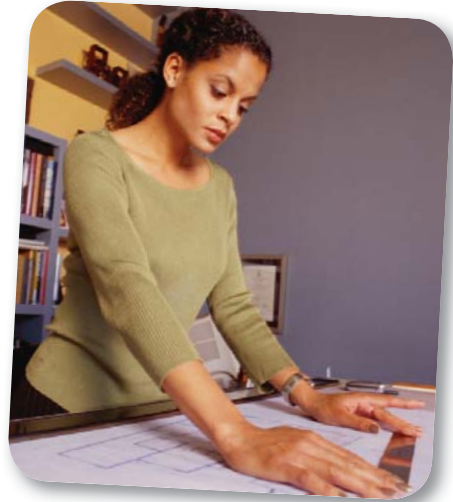

If the deck of the bridge is cracked or unsafe, it may need to be replaced. Renée practises calculating the length of a deck. What is the total length of the deck needed between cable A and cable B, to the nearest tenth of a metre?

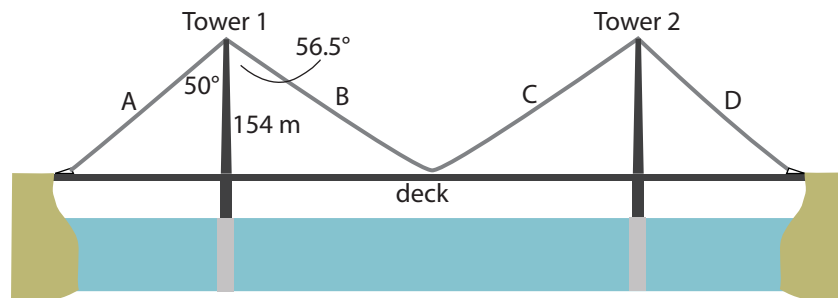

Solution

Renée draws a diagram of the bridge at Tower 1. She notices there are two right triangles in the diagram.

Triangle 1:

- angle: 50°
- height of Tower 1 (adjacent): 154 m
- length of deck (opposite): x

Triangle 2:

- angle: 56.5°
- height of Tower 1 (adjacent): 154 m
- length of deck (opposite): y

Strategy



**Simplify
the Original
Problem**

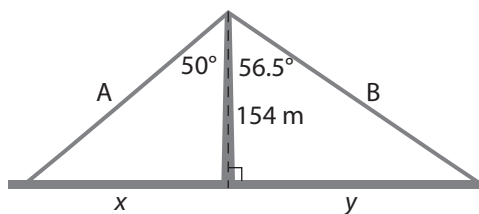

Tan 50° is close to 1.2. That means that the adjacent side is about $\frac{6}{5}$ the length of the opposite side. The deck should be about 186 m.

For each triangle, Renée can use the tangent ratio.

$$\tan \theta = \frac{\text{opposite}}{\text{adjacent}}$$

$$\tan \theta = \frac{\text{opposite}}{\text{adjacent}}$$

$$\tan 50^\circ = \frac{x}{154}$$

$$\tan 56.5^\circ = \frac{y}{154}$$

$$154 (\tan 50^\circ) = x$$

$$154 (\tan 56.5^\circ) = y$$

$$183.530\dots = x$$

$$232.669\dots = y$$

$$\begin{aligned} \text{total length of deck} &= \text{length from cable A to tower} + \text{length from tower to cable B} \\ &= 183.5 + 232.7 \\ &= 416.2 \text{ m} \end{aligned}$$

The total length of the deck between cable A and cable B is 416.2 m.

Your Turn

Bridge inspection assistants check bridge cables to make sure they are in good repair. They can order them to be replaced if they are damaged. Cable A and cable D are the same length. Cable B and cable C are the same length. What is the total length of cable needed to replace cables C and D on the Alex Fraser Bridge? Express your answer to the nearest tenth of a metre.

Check Your Understanding

Try It

For #1 to #4, express your answers to the nearest whole number.

1. a) Determine the length of side x .
- b) Determine the length of side y .

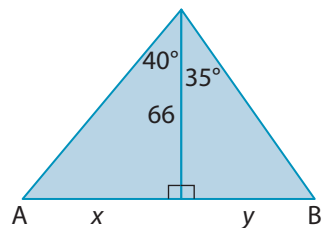

2. a) Determine the length of side m .
- b) Determine the length of side n .
- c) What is the total length from C to D?

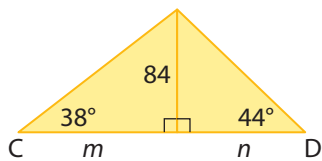

3. a) Determine the length of side r .
- b) Determine the length of side s .
- c) What is the length of side t ?

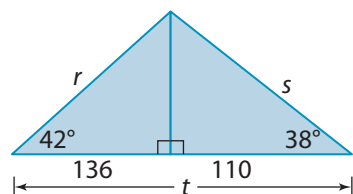

4. a) What is the length of side x ?
- b) What is the length of side y ?

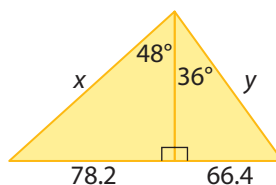

Apply It

5. Madeleine is designing a storage garage.

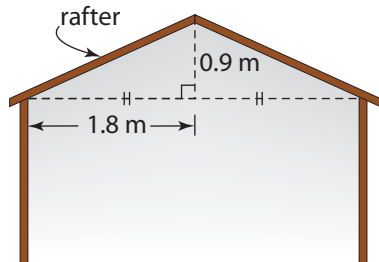

- a) What is the angle of elevation of the rafter?
- b) How much wood is needed for two rafters?

6. A cell phone tower is supported by two guy wires. Wire A attaches to the tower at a 42° angle. Wire B attaches to the tower at a 38° angle. Wire A is anchored 8 m from the base of the tower, and wire B is anchored 6.5 m from the base.

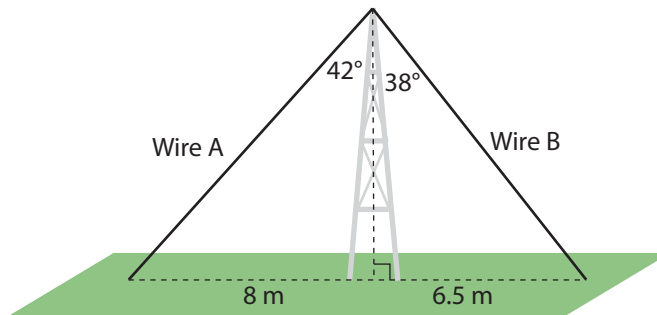

- What trigonometric ratio would you use to determine the length of wire A?
 - What trigonometric ratio would you use to determine the length of wire B?
 - Determine the lengths of both guy wires to the nearest metre.
7. The Fortis Building stands next to TD Place in downtown St. John's, NL. An engineering firm wants to build a walkway between the two buildings. They use the following information:
- The angle of elevation from the top of TD Place to the top of the Fortis Building is 33° .
 - The angle of depression from the top of TD Place to the base of the Fortis Building is 68° .
 - TD Place is 148 ft tall.
 - The buildings are 60 ft apart.

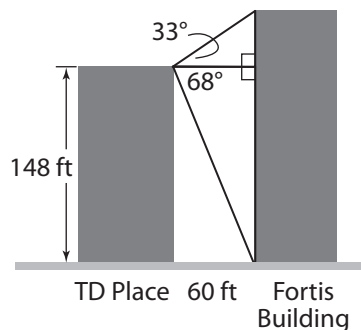

- Identify all the right triangles in the diagram.
- Estimate the height of the Fortis Building.
- Calculate the height of the Fortis Building. Express your answer to the nearest foot.
- How reasonable is your answer in part c)?

On the Job 2

Solve for Angles in Multiple Triangles

Derek installs wooden decks and porches. He is building a deck that leads from a raised door to a backyard. The door is 60" above the ground. There will be two flights of stairs separated by a landing. Before beginning construction, Derek examines a blueprint of the deck. To be safe, flights of stairs should be installed at angles of elevation from 22° to 45° .

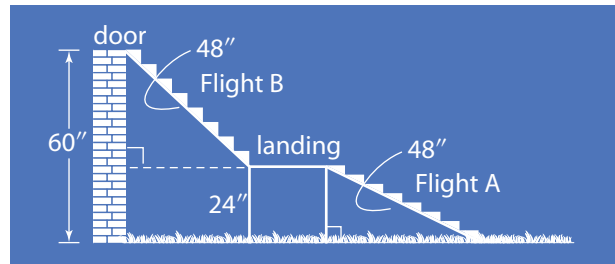

- What is the angle of elevation of flight A? Is it a safe angle?
- What is the angle of elevation of flight B? Is it a safe angle?

F.Y.I.

- the height of a flight of stairs is the rise
- the horizontal length of a flight of stairs is the run
- the hypotenuse is the flight

Solution

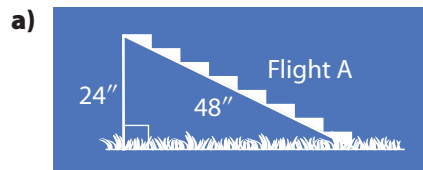

- rise (opposite): 24"
- flight (hypotenuse): 48"

$$\sin \theta = \frac{\text{opposite}}{\text{hypotenuse}}$$

$$\sin \theta = \frac{24}{48}$$

$$\angle \theta = \sin^{-1} \left(\frac{24}{48} \right)$$

$$\angle \theta = 30^\circ$$

$\frac{24}{48}$ is 0.5. What angle has a sine ratio of 0.5?

The angle of elevation of flight A is 30° . This is a safe angle.

$$\begin{aligned}
 \text{b) Height of flight B} &= \text{height of door above ground} - \text{height of landing above ground} \\
 &= 60 - 24 \\
 &= 36
 \end{aligned}$$

The height of flight B is 36".

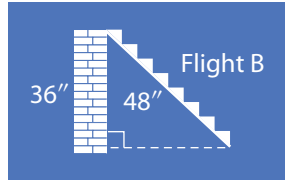

- rise (opposite): 36"
- flight (hypotenuse): 48"

$$\sin \theta = \frac{\text{opposite}}{\text{hypotenuse}}$$

$$\sin \theta = \frac{36}{48}$$

$$\angle \theta = \sin^{-1} \left(\frac{36}{48} \right)$$

$$\angle \theta = 48.590\dots^\circ$$

The angle of elevation of flight B is about 49°. This is not a safe angle.

Your Turn

On another job, Derek builds a similar deck. The door is 20 m above the ground. The landing is 10 m above the ground.

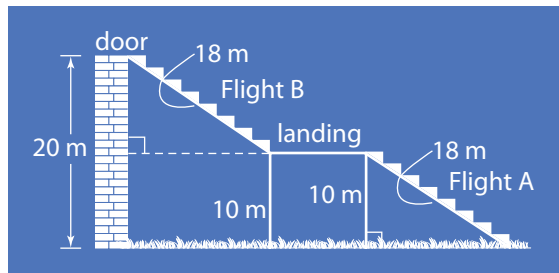

- What is the angle of flight A? Is it a safe angle?
- What is the angle of flight B? Is it a safe angle?

Check Your Understanding

Try It

1. Determine the measure of each unknown angle to the nearest degree.

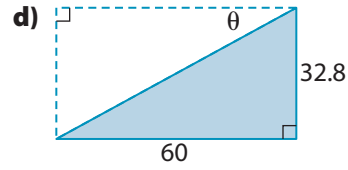
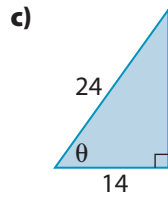
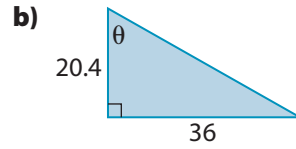
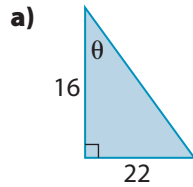

2. Determine the measure of the two indicated angles in the figure, to the nearest degree.

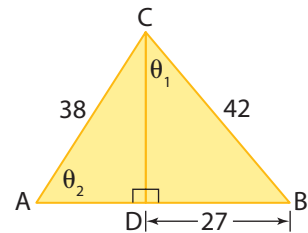

3. Determine the measure of the angles indicated to the nearest degree.

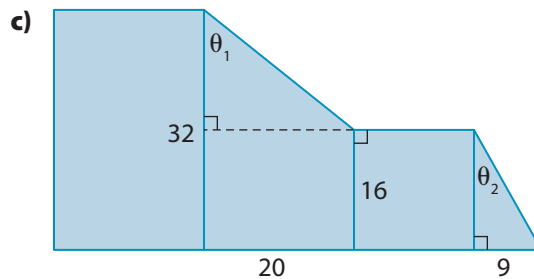
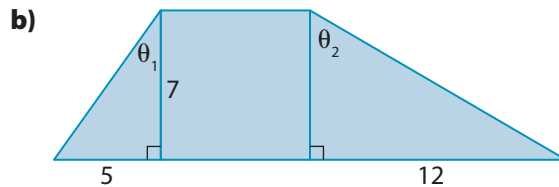
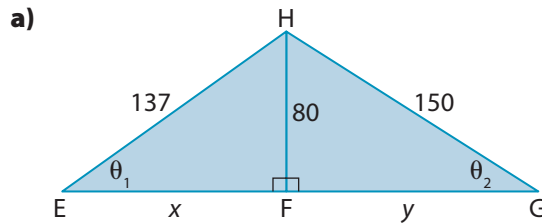

Apply It

4. Christian works at a construction site. Scaffolds are used to reach levels of an unfinished building.
- What is the angle of depression from platform 3 to platform 2?
 - What is the angle of depression from platform 2 to platform 1?
 - Are your answers the same for parts a) and b)? Why or why not?

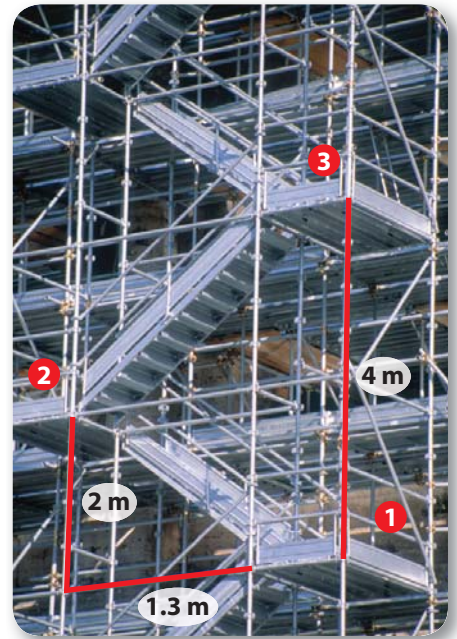

5. Amik loves to build model airplanes. He is building a model of a shuttle-carrier aircraft. On the real carrier, the wings make a 50° angle with the body of the plane, and the tail fins make a 60° angle with the body. Amik's model is shown here. Are the angles on the model accurate?

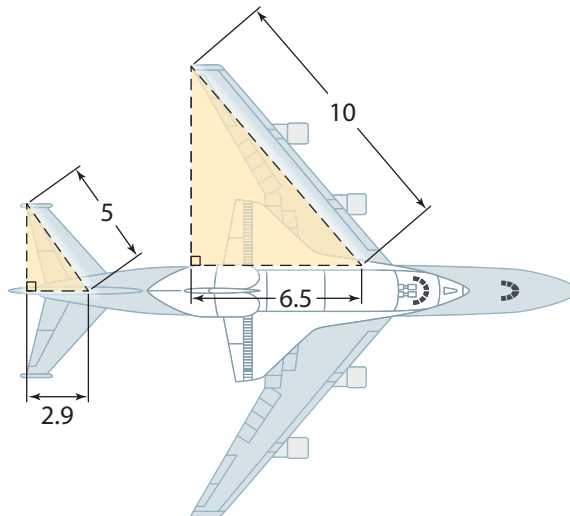

On the Job 3

Solve for Distance and Angles in Multiple Triangles

Taglines are essential safety equipment for using cranes. They are attached to the load of a crane to help steady the load and reduce the amount it swings. A crew of crane operators is moving a large piece of concrete sewer piping. Jeffery and Franc each hold a tagline attached to the piece of piping.

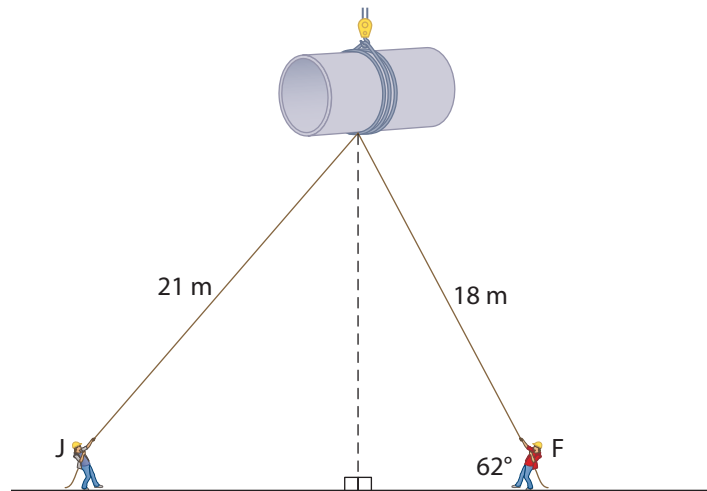

- Franc holds an 18-m tagline at an angle of elevation of 62° . Approximately how high is the piece of piping above the ground?
- Jeffery's tagline is 21 m long. What is the approximate angle of elevation of his tagline, to the nearest degree?

Solution

- angle of inclination: 62°
 - length of tagline (hypotenuse): 18 m

$$\sin \theta = \frac{\text{opposite}}{\text{hypotenuse}}$$

$$\sin 62^\circ = \frac{h}{18}$$

$$18 (\sin 62^\circ) = h$$

$$15.893\dots = h$$

The piece of piping is about 16 m above the ground.

Since Franc and Jeffery are not holding the taglines right at ground level, these answers are approximate.

- b)**
- height of piping (opposite): 16 m
 - length of tagline (hypotenuse): 21 m

$$\sin \theta = \frac{\text{opposite}}{\text{hypotenuse}}$$

$$\sin \theta = \frac{16}{21}$$

$$\angle \theta = \sin^{-1} \left(\frac{16}{21} \right)$$

$$\angle \theta = 49.632\dots^\circ$$

The angle of inclination of Jeffery's tagline is about 50° .

Your Turn

Jeffery and Franc are moving another piece of piping using taglines.

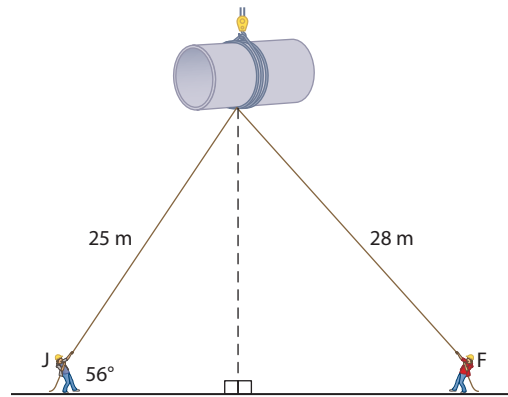

- a)** Jeffery holds a 25-m tagline at an angle of elevation of 56° .
Approximately how high is the piece of piping above the ground?
- b)** Franc's tagline is 28 m long. What is the approximate angle of elevation of his tagline?

Check Your Understanding

Try It

1. Determine the length of x and y in each figure. Express your answers to the nearest whole number.

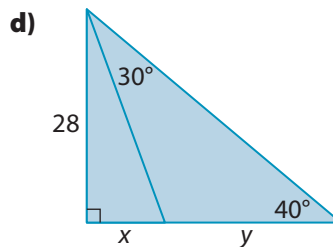
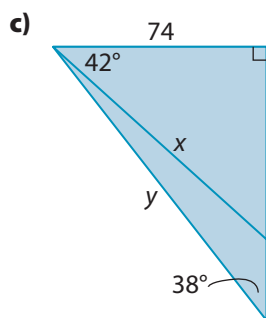
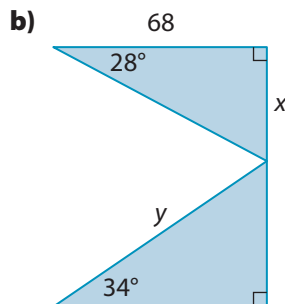
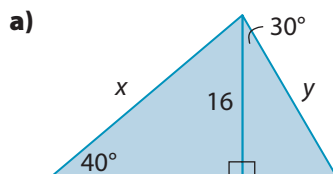

2. Determine the measure of the two unknown angles in each figure. Express your answers to the nearest degree.

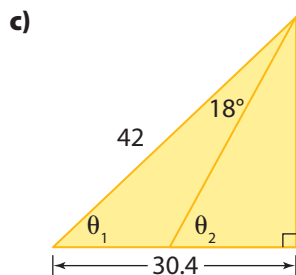
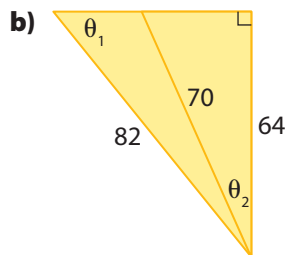
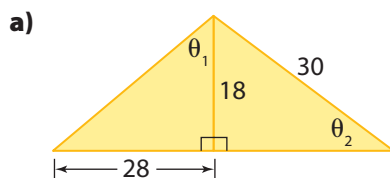

Strategy



Draw or Model

Apply It

3. Janice is interested in nature conservation. She is studying information about how high bald eagles make their nests. Using a clinometer, she sights an eagle nest in a tree at an angle of elevation of 29° . She is 48 m from the tree. Then, she walks closer to the tree until she is 27 m away from it.
 - a) Sketch the situation.
 - b) How many right triangles are in your sketch?
 - c) How high is the eagle nest, to the nearest metre?

4. A surveyor is conducting a geological survey for an engineering firm. The firm will be building a dam across the river.
 - a) How many right triangles do you see in the diagram?
 - b) In your notebook, sketch the right triangles.
 - c) What is the length of side CX in triangle CXY?
 - d) What is the length of side CX in triangle FCX?
 - e) What side represents the height of the cliff?
 - f) How high is the cliff?
 - g) Is your answer for part f) reasonable? Explain.

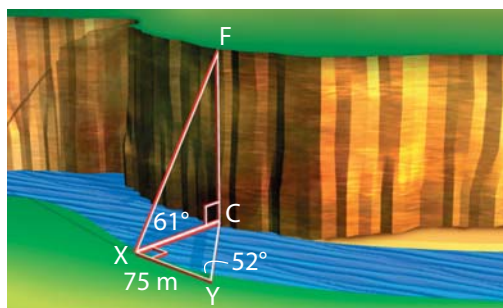

5. Michael is building a cabin near New Glasgow, PEI. Before he builds, he uses a diagram to design the roof trusses.
 - a) How many right triangles do you see?
 - b) Determine the value of the unknown angle.
 - c) Determine the lengths of x and y , to the nearest hundredth of a metre.

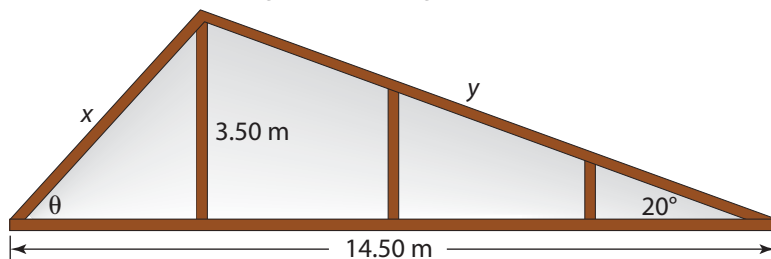

Work With It

Materials

- measuring tape or metre stick

- 1. MINI LAB** Wheelchair ramps must have a 1 : 12 ratio of vertical height to horizontal length to meet safety standards. The safety standards for other types of ramps are different. What are the safety standards for building a skateboard ramp at a skateboard park?

STEP 1

Visit a skateboard park and select two ramps.

STEP 2

For each, measure the horizontal run and vertical rise of the ramp. Record your measurements. Create a diagram of each ramp.

STEP 3

Determine the angle of elevation of each ramp.

STEP 4

What do you think the safe ratio of vertical height to horizontal length is for skateboard ramps? Compare your answers with those of a partner.

- 2.** Jack and Sarah are facing each other on opposite sides of a 10-m flagpole. From Jack's point of view, the top of the flagpole is at an angle of elevation of about 50° . From Sarah's point of view, the angle of elevation is about 35° .

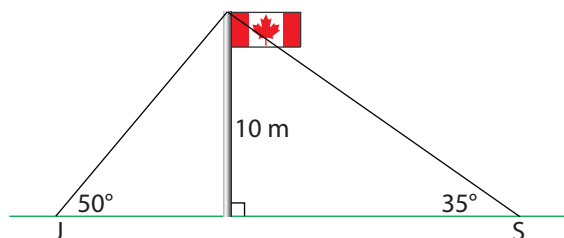

- a) List two methods that Jack and Sarah could use to determine the distance between each other.
- b) Calculate the distance between Jack and Sarah.



3. A surveyor is positioned at the intersection where an on-ramp meets the Route 203 Expressway in Newfoundland and Labrador. It is too dangerous to measure the width of the expressway directly. She places a marker 50 m from the intersection. With her surveying equipment, she records that the marker is at a 64° angle from her current position.

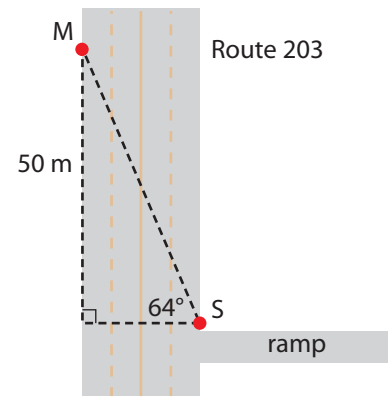

- What is the width of the expressway, to the nearest metre?
- How else could the surveyor determine the width of the expressway, without measuring directly?

Discuss It

Strategy



Develop a Strategy

4.

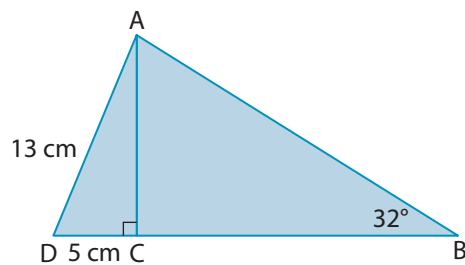

- Outline a plan that you could use to determine the length of side BC .
- Carry out your plan.

5.

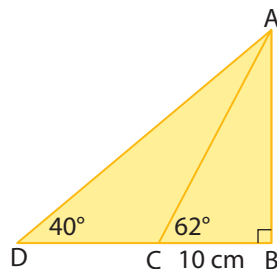

- Outline a plan that you could use to determine the length of side DC .
- Find a classmate who outlined a different plan.
- Carry out both plans.
- Which plan do you prefer? Why?

What You Need to Know

Section After this section, I know how to . . .

- 7.1**
- identify and sketch a given scenario
 - use trigonometric ratios to determine distances and lengths
 - use trigonometric ratios to determine unknown angles
 - solve problems using the three trigonometric ratios
- 7.2**
- use angles of elevation and depression to determine distances and lengths
 - use trigonometric ratios to determine unknown angles of elevation and depression
 - solve problems using angles of elevation and depression
- 7.3**
- identify right triangles in a given scenario
 - use trigonometric ratios to determine unknown angles and lengths
 - determine whether a solution to a problem is reasonable

If you are unsure about any of these questions, review the appropriate section or sections of this chapter.

7.1 Right Triangles, pages 308–321

1. Determine the indicated value in each triangle. Express your answer to the nearest tenth of a unit.

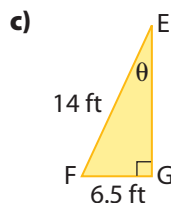
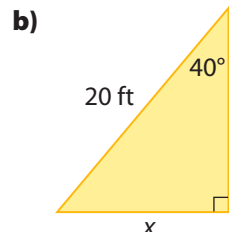
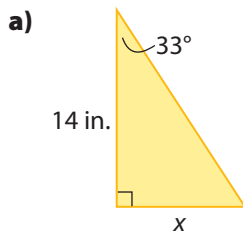

2. The sail of a personal sailboat is in the shape of a right triangle. The sail is 175 cm wide at the bottom. The angle of elevation from the corner of the sail to the top is 65° . How tall is the sail to the nearest tenth of a centimetre?



7.2 Angles of Elevation and Depression, pages 322–337

- Josie is on a ladder washing windows. The ladder makes an angle of elevation of 75° with the ground. If the windows are 24 ft above the ground, how long should the ladder be? Sketch the scenario and show your work.
- Some farmers use a hay elevator to move small bales of hay into their hayloft. The base of this hay elevator is 8.5 m from the barn. The loft opening is 5.5 m above the ground. The hay elevator is old and can move hay at an angle of elevation of no more than 15° . Can this elevator be used to put hay into this loft? Explain your reasoning

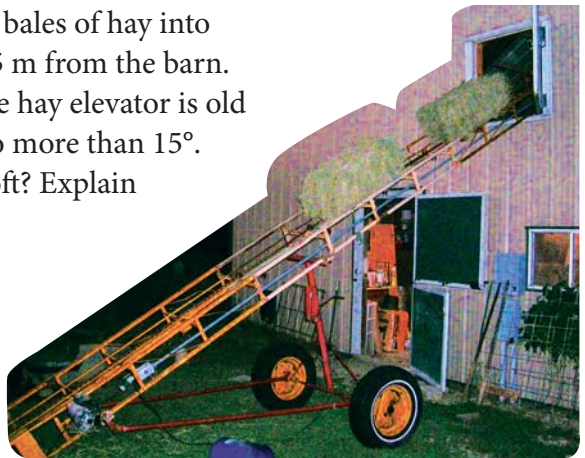

7.3 Multiple Right Triangles, pages 338–353

- Determine the measure of $\angle CAD$.
 - Determine the measure of $\angle DAB$.

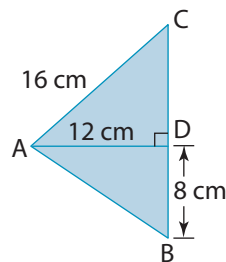

- A radio antenna is supported by two guy wires. Wire 1 is 35 ft long and makes an angle of elevation of 44° with the ground. Wire 2 is attached to the ground 17 ft from the base of the antenna and makes an angle of elevation of 55° with the ground. Both wires are attached to the top of the antenna.
 - Sketch the scenario.
 - How tall is the antenna? Express your answer to the nearest foot.
 - Check your answer.

Test Yourself

For #1 to #4, select the best answer.

1. What is the angle of elevation of the ramp?

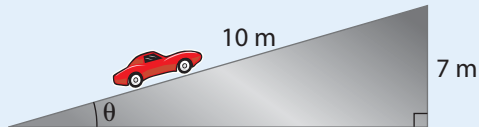

- A 60° B 56° C 44° D 30°

2. How tall is the building?



- A 50 m B 64 m C 84 m D 93 m

3. How long is the ladder?

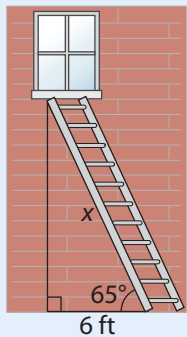

- A 10 ft B 12 ft C 14 ft D 18 ft

4. What is the diagonal distance from the top of the cliff to the ship?

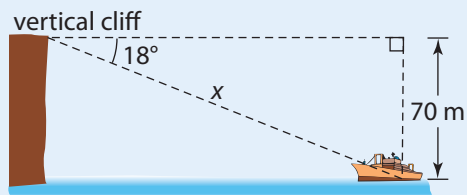

- A 110 m B 205 m C 227 m D 258 m

5. Dennis is using a conveyor mounted on a truck to move shingles to a rooftop. The house is 7.5 m tall. The truck is 14.6 m from the house.
- Draw and label a sketch of the situation.
 - Determine the angle of elevation needed to clear the rooftop of the house.
 - How long should the conveyor be? Express your answer to the nearest tenth of a metre.
6. The Macdonald Bridge in Halifax, NS, is being inspected. The height of Tower 1 is 102 m. Cable A makes an angle of 68° with the tower. Cable B makes an angle of 76° with the tower. What is the length of the deck from cable A to cable B?

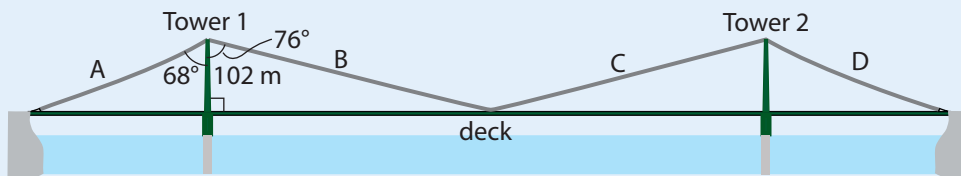

7. Lisa works for the city maintenance department. She has been asked to install two guy wires to support a new flagpole in the town square.

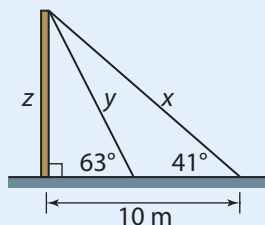

- Determine the amount of cable needed for the first wire (x).
- Determine the height of the flagpole (z).
- Determine the amount of cable needed for the second wire (y).
- Determine the total amount of cable Lisa will need, to the nearest metre.



Design a Wheelchair Ramp

Many people in wheelchairs have a difficult time using community facilities. You are a member of a committee working to make your community more accessible.

1. Identify a location that needs a wheelchair ramp. It could be in your school, a community centre, or a local business.
 - ✓ Measure the distance from the ground to the bottom of the door.
 - ✓ Wheelchair ramps must not have a slope greater than 4.5° .
Calculate how far back from the door the ramp must start.
2. Check the safety of your design.
 - ✓ How wide is the ramp?
 - ✓ Is there a proper landing at the top and bottom?
 - ✓ Does it include handrails?
 - ✓ Is the ramp too long to fit safely in this location? If so, alter your design to make it safe. For example, you could turn the ramp.
 - ✓ Make any landings large enough for someone in a wheelchair to turn.
3. Draw a diagram of your design. Show the lengths and angles you used for your calculations.



Web Link

For information on safe wheelchair ramps, go to www.mcgrawhill.ca/school/learningcentres and follow the links.

What Is Your Strategy?

Play Kono with a partner. Kono is a traditional Korean game of strategy.

1. Create a 5-by-5 game board in your notebook or on a separate piece of paper.
2. Set up your pieces as shown.

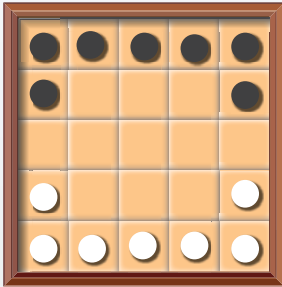

3. Flip a coin to determine who starts. Move one game piece each turn. The piece can move diagonally forward or backward one square on each turn.
4. The winner is the first player to move all their game pieces to the opposite side of the board.
5. Play the game several times and with several different partners. Determine the best strategy for winning the game.
6. Design your own adaptation of this game.

Materials

- checkers, game pieces, or coins (7 pieces of 2 types)

Web Link

To play this game online, go to www.mcgrawhill.ca/school/learningcentres and follow the links.